

The lower-case letters in Table 1 correspond to the following dimensions. Unless otherwise stated, all values are maximum dimensions.

Table 1:

a	Length	30.0
b	Width	15.5
c	Total height	6.5
d	Equipment height above	2.2
e	Assembly height below	3.3
f	Board thickness	1.0
g	Distance between the center of the socket strip and the edge	2.8 exact
h	Area to be kept clear on the underside	4.8
j	Area with reduced equipment height	5.8
k	Reduced assembly height	2.8

The bridge of plugs must be located from the edge of the PCB as shown in Fig. 1. The decoder may be shorter than L = 30 mm.

The maximum height of the decoder is given and must be observed. Fig. 2 shows the assembly.

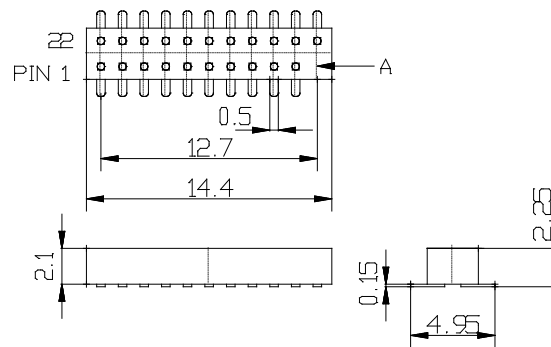

Fig. 2: Typical socket connections for decoders, A = Index position Pin 11

2.1.2. System PCB

The system PCB provides the housing for the decoder according to its maximum dimensions, without using any force to plug in. Sufficient space should be provided to install or uninstall the decoder without any special tool. A suitable male pin arrangement shows Fig. 3.

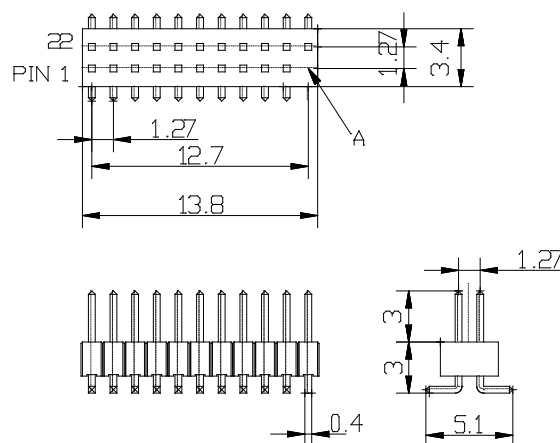

Fig. 3: Typical pin header for vehicles, A = Index position Pin 11

Male and female plugs have common dimensions of this type of connections. The male plugs consist of a length of 3 mm and have either a square profile of 0.40 x 0.40 mm shape or a round profile with 0.43 mm diameter. The surface is gilded and allows a maximum current of 1A.

2.1.3. Decoder-Mounting

It is possible to mount the decoder in two different positions.

2.1.3.1 Compact variant

The compact mounting results in the smallest space requirements. In this case the decoder is plugged in with the female plugs on top. The male pins make contact through the PCB of the decoder. The decoder sits plane on the system PCB.

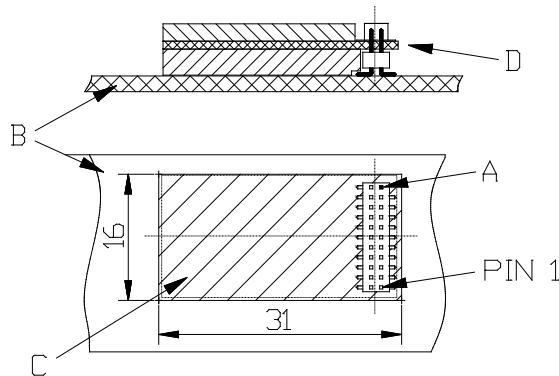

Fig. 4: Compact variant
 A = Index position Pin1
 B = Circuit board in the vehicle
 C = On the board in the vehicle of components area to be kept clear
 D = Decoder board

2.1.3.2 Rotated variant

If there is enough height available, but no free space on the vehicle board, the vehicle manufacturer can use the rotated variant. The decoder is plugged in with the socket facing downwards (towards the vehicle circuit board). The assignment of the connector on the vehicle circuit board must be mirrored in the axis of pin 6 and 17.

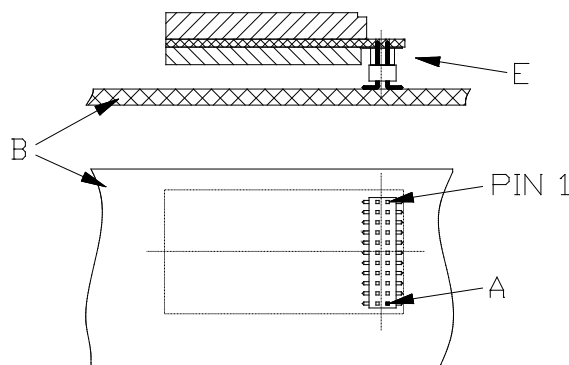

Fig. 5: Rotated variant
 A = Index position Pin 11
 B = circuit board in the vehicle
 E = Pin header

Vehicles with a factory-installed interface to this standard must be clearly marked with the logo 21MTC on the packaging:



2.2 Electrical Characteristics

Manufacturers of this decoder must specify the maximum current allowed to drawn for each output. Connections that are not used on the vehicle side should be routed to soldering points on the vehicle mainboard.

2.3 Pin Assignments of the interface for using decoders

The pin assignments for 21MTC are defined in Table 2:

Table 2: Pin assignments, description and definition of function

Pin	Name	Description	Group
1	Input1	Sensor-Input 1, alternate output 7 ¹⁾	4
2	Input2	Sensor-input 2, alternate output 8 ¹⁾	4
3	AUX6	Output 6 ¹⁾	8
4	AUX4	Output 4 ¹⁾	8
5	ZBCLK	Trains Bus Clock, alternate output 9 ¹⁾	7
6	ZBDTA	Train Bus Data (TxD, RxD), alt. output 10 ¹⁾	7
7	F0r	Light direction rear	5
8	F0f	Light direction forward	5
9	LS/A	Speaker Connection A	6
10	LS/B	Speaker Connection B	6
11	Index	Not used, Orientation	
12	Vcc	Internal Decoder-Voltage 1.8 – 5.7 Volt	2
13	AUX3	Output 3 ¹⁾	8
14	AUX2	Output 2	5
15	AUX1	Output 1	5
16	V+	Decoder Plus, referenced at rectifier, port storage capacitor	2
17	AUX5	Output ¹⁾ 5	8
18	Motor2	Motor-connection #2 minus ²⁾	3
19	Motor1	Motor-connection #1 plus ²⁾	3
20	GND	Decoder Ground minus, referenced ar rectifier	2
21	Power pick-up left	Power pick-up left in direction forward	1
22	Power pick-up right	Power pick-up right in direction forward	1

¹⁾ It should be noted that when the decoder processor is being started, uncontrolled states including a high-resistance state at the outputs with logic level can occur for a short time. Critical hardware on the mainboard must be secured accordingly.

²⁾ The specified polarity refers to the motor connections for direction of travel 1 (forward) as per NEM 631.

Annotations for the Groups:

- Group 1:** When supplied with AC-Motors Pin 21 is connected to the wheels and Pin 22 to the power pick-up to the center conductor.
- Group 2:** Pin 12 (Vcc) is not mandatory. It is recommended to use this connection only for the access bus interface.
- Group 3:** Pin 19 is field coil A, Pin 18 is field coil B for AC-Motors.
- Group 4:** Pin 1 and 2 are open collector inputs and are switched to GND. The input resistance should be approx. 100 kΩ. Sensor-Input 1 should be used for wheel synchronization on steam locomotives.
These pins can also be used as function outputs with logic levels according to group 8.
- Group 5:** In case the rear lights are connected to the decoder separately, the rear lights of vehicle in forward direction 1 are switched with Pin 15 and those in rear direction 2 with Pin 14.
- Group 6:** The speaker impedance is defined by the decoder manufacturer and is as such documented.
- Group 7:** The microcontroller-pins of the train bus are connected through a serial resistor with a maximum of 470 Ω.
These pins can also be used as function outputs with logic levels according to group 8.
- Group 8:** Outputs are defined as logic-level according to Table 3D, against GND and with maximum load 0.5 mA.

Table 3:

	Voltage Level Decoder Output	Voltage Level for switching element on system board
Function Switched Off	≤ 0.4 V	≤ 0.8 V
Function Switched On	≥ 2.4 V	≥ 2.0 V

3. Operation without Decoder

When operating without a decoder, a female jumper plug must be used, which connects at least the power pick-up of right rail (Pin 22) with Motor1 (Pin 19) and Power pick-up of left rail (Pin 21) with Motor2 (Pin 18).

If lights exist the appropriate pins on the jumper plug must be bridged.

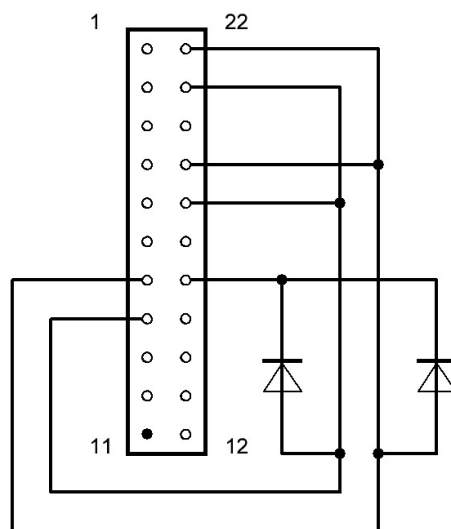

Fig. 6: Typical Jumper plug

Depending of the wiring of the function outputs in the vehicle, the vehicle manufacturer can produce a jumper plug specific to the vehicle that connects other outputs.